

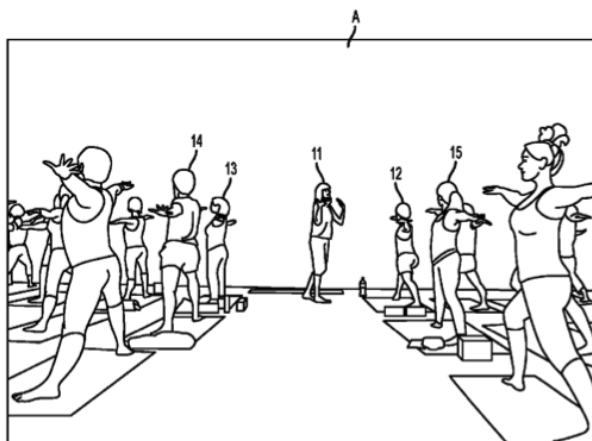

## YogaGlo Patent Loses Its Shine

By: [Sharon Adams](#)



YogaGlo Patent # 8,605,152, Figure 1

### INTRODUCTION

There has been much [controversy](#) in the yoga community about the recent issuance of a [patent to YogaGlo](#). The YogaGlo patent contains claims for videoing a yoga instructor teaching students, with an unobstructed line of sight from video camera to the instructor.

There are so many problems with the YogaGlo patent that it's hard to get them all into one article. The YogaGlo patent is susceptible to both defensive and offensive attacks. For example, one offensive approach might involve post-grant review proceedings under the new [AIA procedures](#). More on the AIA procedures at a later time.

For now, this article discusses a defensive approach that might be used if YogaGlo claimed someone is infringing its patent. This approach involves an analysis of the scope the claims in the YogaGlo patent under the legal theory of "prosecution history estoppel." The patent prosecution history (the objections made by the patent examiner and the responses made by the applicant) shows that the YogaGlo patent claims have a very narrow scope. Therefore, except in very specific circumstances, this YogaGlo patent is unlikely to be the basis for a valid claim of infringement.

### PATENTS ARE A PROPERTY RIGHT WITH DEFINED BOUNDARIES

Patents are a temporary monopoly granted as a right under the [U.S. Constitution, Art. I, § 8, cl.8](#). Like any property right, the boundaries must be clear. Therefore, patent claims are frequently interpreted according to the exact words claimed -- the literal words of each claim --



and infringement is found only if the accused invention infringes each literal element of a claim.

In addition to literal infringement, courts have also recognized that the “[language in the patent claim may not capture every nuance of the invention.](#)” Therefore courts have developed the Doctrine of Equivalents. Under this Doctrine, the “scope of the patent is not limited to its literal terms but instead embraces all equivalents to the claims described.” *Festo*, 522 U.S. at 733.

The Doctrine of Equivalents was refined and clarified by the U.S. Supreme Court case of *Festo Corp. v. Shoketsu Kinzoku Kogyo Kabushiki Co., Ltd*, 535 U.S. 722, 731 (2002). *Festo* analyzed the scope of claims that had been amended during the examination proceedings, and how the Doctrine of Equivalents applied to these amended claims.

Claim amendment is a standard procedure during patent prosecution. In the U.S., Patent prosecution begins with filing a patent application containing drawings, a specification and claims with the United States Patent & Trademark Office. The application is assigned to a patent examiner. Frequently, after reviewing an application, the examiner will reject the claims for a variety of reasons. And, in a response to the rejection, applicants often amend the claims. This is what happened during the patent prosecution of the patent at issue in *Festo*, and also what happened during prosecution of the YogaGlo patent application.

In *Festo*, the patent examiner rejected the original claims and the applicant amended the claims to overcome the rejection. As the Court explained, in these instances, the claim amendment is “taken as a **concession** that the **invention as patented does not reach as far as the original claim.**” *Festo*, 535 U.S., at 734 (emphasis added).

The Supreme Court held that prosecution history estoppel arises when a claim amendment is made to secure the patent and the amendment narrows the patent’s scope. Unless an amendment “is truly cosmetic” then the specific reason for amendment is irrelevant, and the scope of the claims will be defined by the patent prosecution history.

In *Festo*, the Court recognized the tension between claim amendment and the Doctrine of Equivalents, stating: “By amending the application, the invention is deemed to concede that the patent does not extend as far as the original claim. It does not follow, however, that the amended claim becomes so perfect in its description that no one could devise an equivalent.” *Festo*, 535 U.S., at 738.

#### **ANALYSIS OF YOGAGLO CLAIM 1 UNDER FESTO**

*Festo* explained that prosecution history estoppel applies whenever there has been a claim amendment during patent prosecution. Once there has been such a claim amendment, the applicant bears the burden of rebutting the presumption of prosecution history estoppel. *Festo*, 535 U.S., at 740-41.



The YogaGlo patent claims were amended during patent prosecution and thus, prosecution history estoppel is relevant to determining the scope of these claims.

Claim 1 of the YogaGlo patent claims a system for videoing a yoga class, with a video at the rear of the room at a height of “about three feet” and having an “unobstructed” line of sight to the instructor. (Claim 1 is illustrative of the claims in the YogaGlo patent, and is set forth at the end of this article, with **bold** indicating claim amendments.)

Originally, when the application was filed, YogaGlo claimed a system for shooting a yoga video with a line of sight corridor to the instructor, and a plurality of students between the video camera and the instructor.

The patent examiner rejected original claim 1, stating that it was obvious under 35 USC §103, in light of other references claiming video instruction. The examiner referenced the Khalsa patent application (US 2002/0051958). As seen in the figure below, Khalsa shows video camera 104 filming instructor 101 who is teaching a class with students 103.

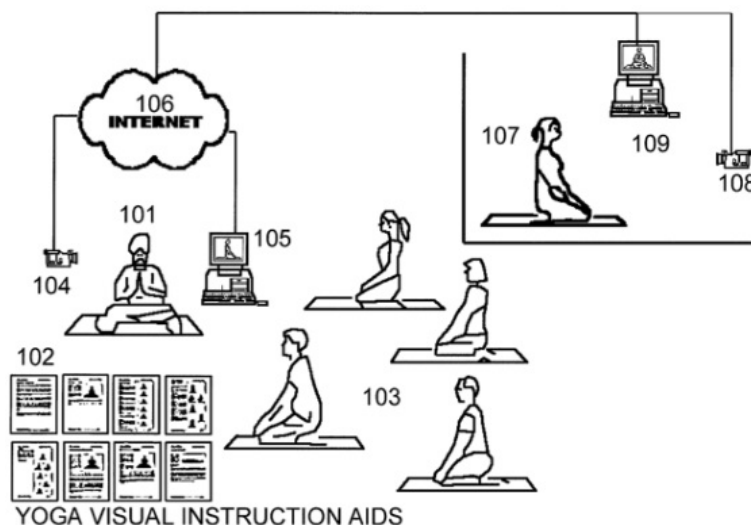

In addition, the examiner referenced Saleh (US 8,208,002). The figure below from the Saleh patent shows video camera 514 above the heads of the students, filming the presenter, located at presenter podium 504.

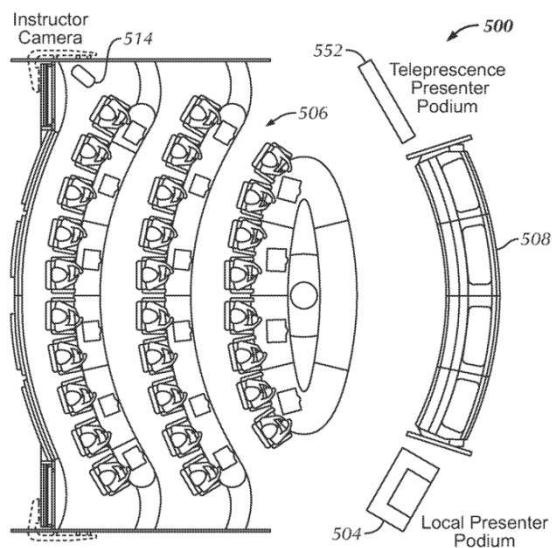

In response to this rejection (and other rejections), the applicant amended claim 1 and added the limitation that the video camera must be at the rear of the room at a height of “about three feet”. Applicant responded to the examiner’s rejections by noting that Salah has the camera placed close to the ceiling, while in the YogaGlo application, the camera was at student level. Applicant responded to the second reference by arguing that Khalsa does not disclose an unobstructed line of sight.

Applicant’s arguments and amendments were in response to specific rejections from the patent examiner. Applicant amended Claim 1 to add the limitation that the camera must be at “about three feet” to overcome the prior art. Thus, it is immediately apparent that any video of a yoga class where the camera is at ceiling height, as in Saleh, will not infringe the YogaGlo patent. Furthermore, because of prosecution history estoppel, any yoga video with a camera height other than “about three feet” is most likely **not** going to infringe the YogaGlo patent.

In addition to the claim limitations found in the prosecution history, there is also an inherent limitation in the claims involving time. The patent does not claim a time frame for filming a yoga instructor with the camera at about three feet height, and with an unobstructed view of the instructor. However, it is apparent that the only reasonable interpretation of Claim 1 requires that the entire class must be filmed in accordance with the claims of the patent. First, there is no indication in the specification, drawings or claims that the YogaGlo video camera moves at all. Therefore, it is unlikely that any yoga video using a mobile video camera, moving around the room for different views, would infringe the YogaGlo patent.



Second, because of existing prior art, if a mobile video camera pans through a shot where the camera is about three feet high and with an unobstructed view of the instructor, such a video would be unlikely to infringe the YogaGlo patent. There is ample prior art showing this filming technique. See, for example, the screen shot of a Forrest Yoga DVD, filmed before the filing date of the YogaGlo patent application. But, a discussion of the use of prior art is for another article.



Screen shot from the "[Forrest Yoga with Ana Forrest, Strength & Spirit](#)" DVD © 2005

Claim 1 states:

"A system for automatically producing a video representation of a yoga class configured so a remote viewer enjoys the experience of being in a real yoga class, the system comprising:

a studio having a front area and a rear area;

an instructor position located in the front area and facing the rear area;

a line of sight corridor disposed between **the rear area and the instructor**;

a plurality of students at student positions, facing the instructor position, distributed across the studio between the instructor position and the image capturing device wherein the student positions do not impinge upon the corridor;

an image capturing device for capturing video located in the rear area **disposed to**



**provide a participatory view from a height of about three feet by capturing through the line of sight corridor, an unobstructed video of the instructor in the instructor position including images of the students disposed along the sides of the line of sight corridor; and**  
sound capture equipment to capture at least audio of the instructions given by the instructor disposed in the instructor position to the students disposed in the student positions.

During patent prosecution, the claim was similar to the non-bolded language. The bolded language indicates a significant addition to Claim 1.